

High Brightness UV LED Lamp



5mm Through-Hole Package

BL-LBUV5B15C series

FEATURES	APPLICATIONS
<ul style="list-style-type: none"> • Mega Bright UV LED. • InGaN on Silicon Carbide (SiC) die. • 5mm bullet shaped resin mold. • Water Clear Lens. • Narrow viewing angle for concentrated power. 	<ul style="list-style-type: none"> • Epoxy Curing • Currency validation / detection • Bacteria detection. • Medical and forensics. • Decorative /Accent Lighting

PACKAGE OUTLINE DIMENSIONS:

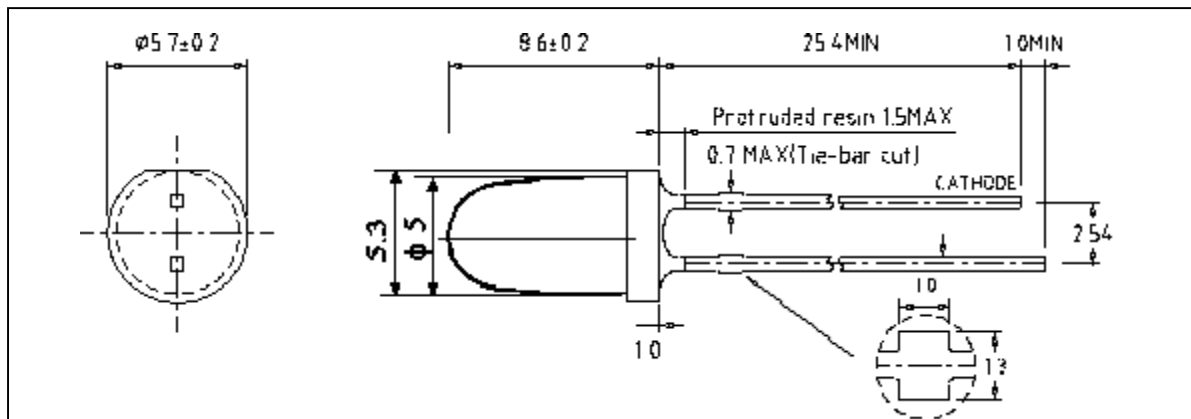

Lead Stoppers Optional

NOTES:

1. All dimensions are in millimeters.
2. Tolerance is ± 0.25 mm unless otherwise noted.
3. Lead spacing is measured where the leads emerge from the package.
4. Specifications are subject to change without notice.

BEAM RADIATION PATTERN

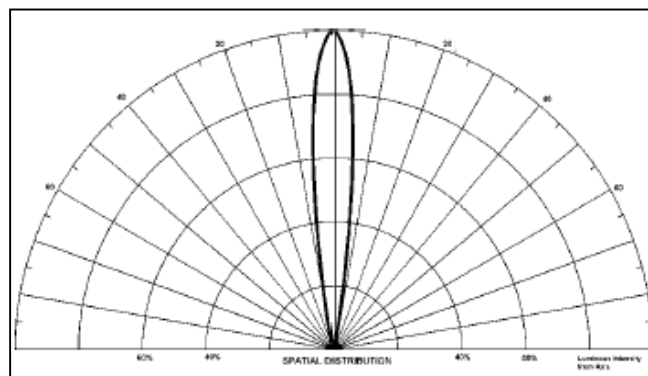

High Brightness UV LED Lamp

5mm Through-Hole Package

BL-LBUV5B15C series



ABSOLUTE MAXIMUM RATING (at $T_A = 25^\circ\text{C}$)

Parameter	Symbol	Value	Unit
Continuous Forward Current	I_F	30	mA
Peak Forward Current (1/10 Duty Cycle, 0.1msec Pulse width)	I_{Fp}	100	mA
Power Dissipation	P_d	120	mW
Forward Voltage	V_f	4.2	V
Reverse Voltage	V_R	5.0	V
Operating Temperature	T_{opr}	-40 to +85	$^\circ\text{C}$
Storage Temperature	T_{stg}	-45 to +100	$^\circ\text{C}$
Lead Soldering Temperature (1.6mm (0.063") from body)	260 $^\circ\text{C}$ for 5 seconds		

ELECTRICAL / OPTICAL CHARACTERISTICS (at $T_A = 25^\circ\text{C}$)

Parameter	Symbol	Min	Typ	Max	Unit
Forward Voltage	$I_F = 20\text{ mA}$ V_F		3.8	4.2	V
Total Radiant Flux	$I_F = 20\text{ mA}$ P	4		12	mW
Radiant Intensity (on optical axis)	$I_F = 20\text{ mA}$ I_r		30		mW/sr
Peak Wavelength	$I_F = 20\text{ mA}$ λ_p	395	400	410	nm
Spectrum Radiation Bandwidth	$I_F = 20\text{ mA}$ $\Delta\lambda$		26		nm
Viewing Angle	$2\theta_{1/2}$	12	15	18	deg
Reverse Current	$V_R = 5\text{ V}$ I_R		10	100	μA

Operating Warning Notes:

This device radiates intense Ultra Violet (UV) light when operated. Most of the UV radiation is not visible. Exposure to UV can be harmful to your health. Proper eye and skin protection is recommended. Do not look directly at the device during operation. Even brief exposure can produce eye damage.

High Brightness UV LED Lamp

5mm Through-Hole Package

BL-LBUV5B15C series



TYPICAL ELECTRICAL CHARACTERISTICS CURVES (at 20 mA DC / $T_A = 25^\circ\text{C}$)

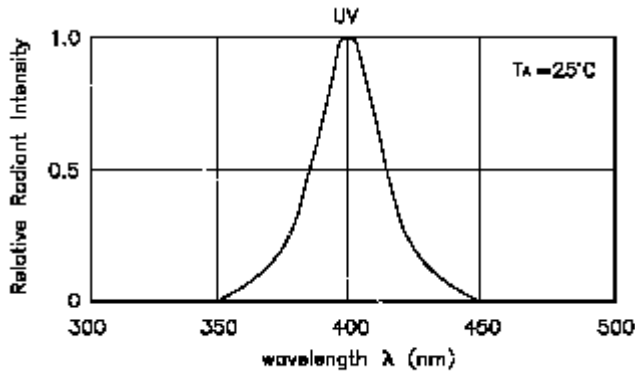

RELATIVE INTENSITY Vs. WAVELENGTH

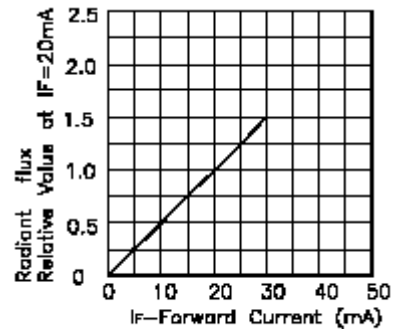

RADIANT FLUX Vs. FORWARD CURRENT

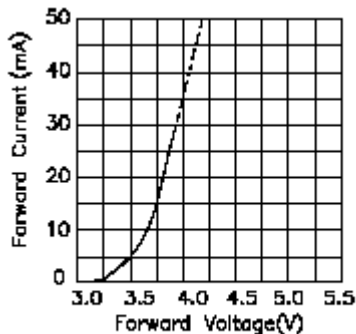

FORWARD CURRENT Vs. FORWARD VOLTAGE

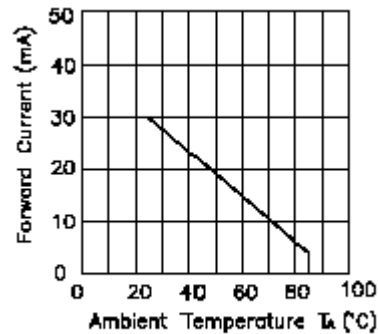

FORWARD CURRENT DERATING CURVE

GENERAL NOTES:

1. Total Radiant Flux (P), a radiometric measurement, is obtained by measuring with an integrating sphere and a light sensor filter combination (spectroradiometer) and is the Total Light Energy (Flux) emitted by the LED lamp in all directions (isotropic). Radiant Intensity (I) is the portion of the light energy within a 3° solid angle in the optical axis.
2. Total Radiant Flux measurement uncertainty is $\pm 15\%$ due to test procedures and equipment variations.
3. $\theta_{1/2}$ is the off-axis angle at which the luminous intensity is half the axial luminous intensity. Tolerance $\pm 3^\circ$.
4. Dominant wavelength is derived from the 1931 CIE 2° Observer Chromaticity Diagram.
5. Peak and Dominant wavelength measurement uncertainty is ± 0.05 due to variations.
6. Caution for ESD: Static Electricity and surges can damage the LED. It is recommended using a wristband or anti-electrostatic glove when handling the LED. All devices, equipment and machinery must be properly grounded.
7. Do not apply excess mechanical stress to the leads, especially when heated or while soldering.

High Brightness UV LED Lamp

5mm Through-Hole Package

BL-LBUV5B15C series



PRODUCT CODE BREAKDOWN

